

POS	QTY	SUPPLIER	PART NUMBER	DESCRIPTION	MATERIAL
01	1 EA	BORAIID AUTOMATION	2024-1274-MK01-00	RABBIT CATCHER	CARBON STEEL
02	1 EA	BORAIID AUTOMATION	2024-1274-MK02-00	RABBIT CATCHER CAP	CARBON STEEL
03	1 EA	VICTAULIC	STYLE 77	3 INCH FLEXIBLE COUPLING	-

**NOTES:**

- FOR SAFE OPERATION, ADEQUATE SHUT OFF VALVES MUST BE INSTALLED UPSTREAM BY END USER. IT IS THE END USER'S RESPONSIBILITY TO ENSURE ALL ENERGY IS ISOLATED BEFORE OPENING PIPING.

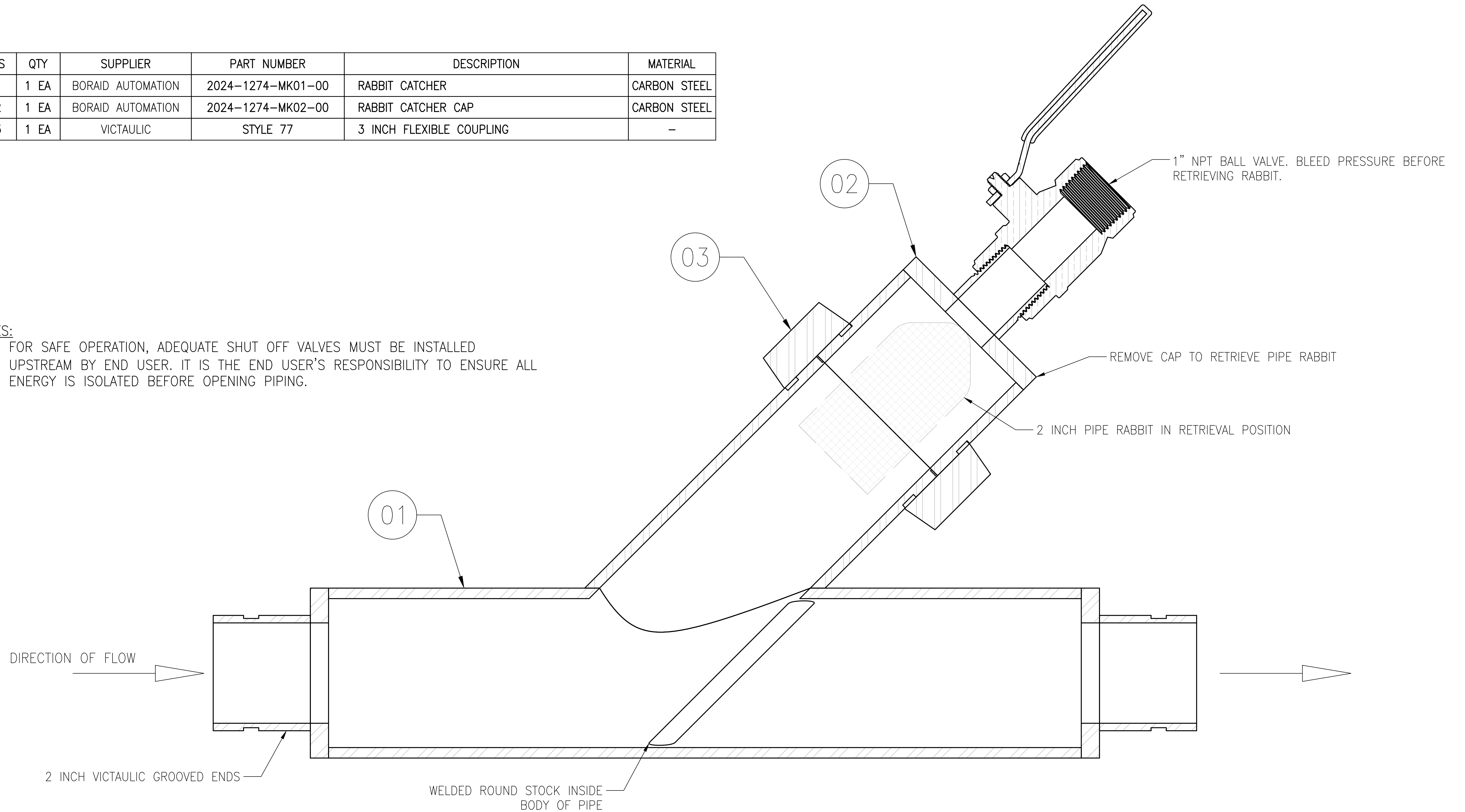

FILE NAME: 2025-1274-00 TBM RABBIT CATCHER.DWG; PRINT DATE: 10/28/2025

REV	DATE	BY	APP	DESCRIPTION

DESIGNED BY	N. DUNCAN
DRAWN BY	N. DUNCAN
CHECKED BY	J. JONASEN
IN CHARGE	J. JONASEN
DATE	2025-10-28

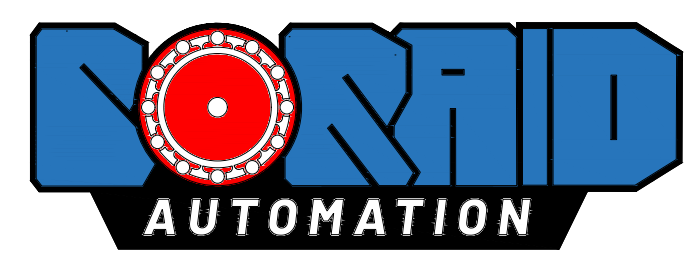

3050 E. AIRPORT WAY  
LONG BEACH, CA 90806  
562.264.2500

TBM RABBIT CATCHER GENERAL OVERVIEW		CATALOG NO	2025-1274-00
		DRAWING NO	2025-1274
		REV	00
		SCALE	1:1
		SHEET NO	01