

POS	QTY	PART NUMBER	SUPPLIER	DESCRIPTION	MATERIAL
1	1 EA	2025-1253-MK01.01	BORAID AUTOMATION	SOFRASAR TYPE 1/ZU LIFTING INSERT - BASE	1018
2	1 EA	2025-1253-MK01.02	BORAID AUTOMATION	SOFRASAR TYPE 1/ZU ATTACHMENT - FLANGE	1018
3	4 EA	2025-1253-MK01.03	BORAID AUTOMATION	SOFRASAR TYPE 1/ZU ATTACHMENT - HAMMER TAB	1018
4	1 EA	HR-1000 1068050	CROSBY	SWIVEL LIFTING EYE - 10K CAPACITY	-

**NOTES:** 1. FOR USE WITH SOFRASAR TYPE 1 SOF LIFT 180 PLASTIC PCTL INSERTS.  
2. LIFTING CAPACITY DETERMINED BY END USER

REV	DATE	BY	APP	DESCRIPTION

DESIGNED BY	N. DUNCAN
DRAWN BY	N. DUNCAN
CHECKED BY	J. JONASEN
IN CHARGE	J. JONASEN
DATE	10/15/2025



3050 E. AIRPORT WAY  
LONG BEACH, CA 90806  
562.264.2500

OPTIMAS-SOFRASAR TYPE 1 SOF LIFT 180 LIFTING ATTACHMENT		CATALOG NO.	2025-1253-MK01-00
ASSEMBLY DRAWING		DRAWING NO.	2025-1253-00
		SCALE	2:1
		SHEET NO	1

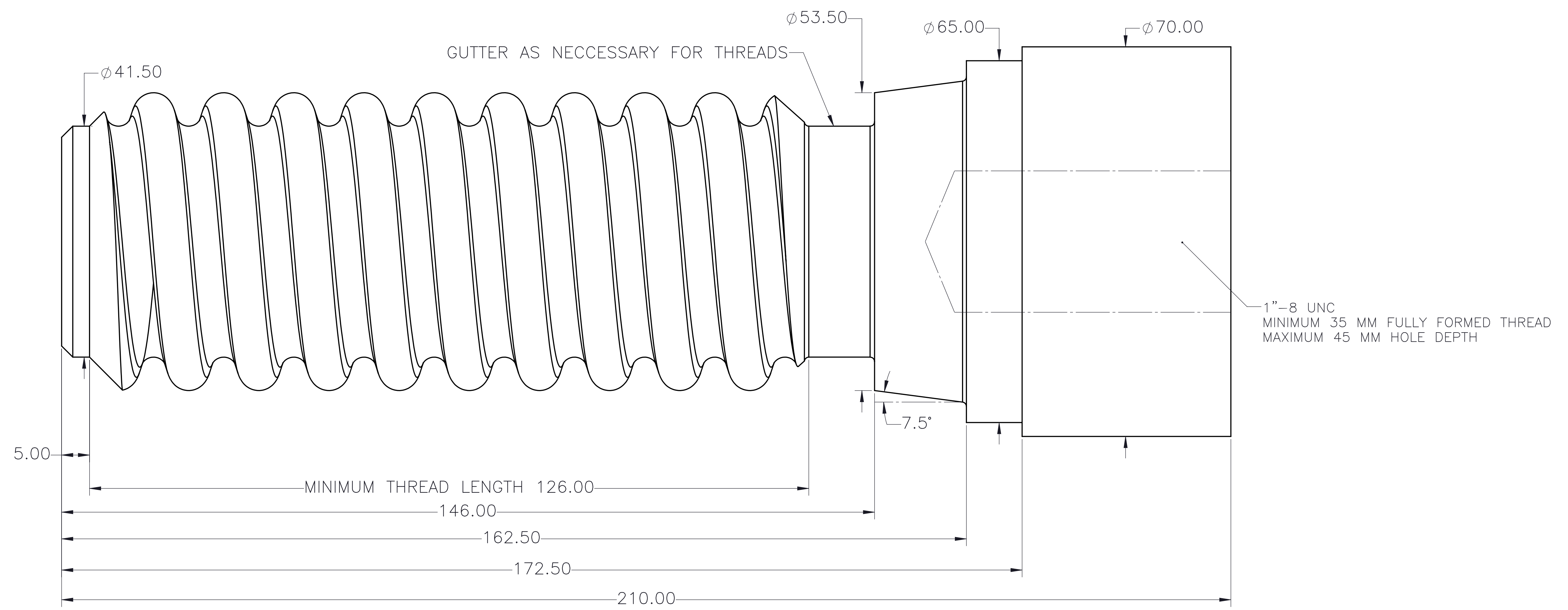
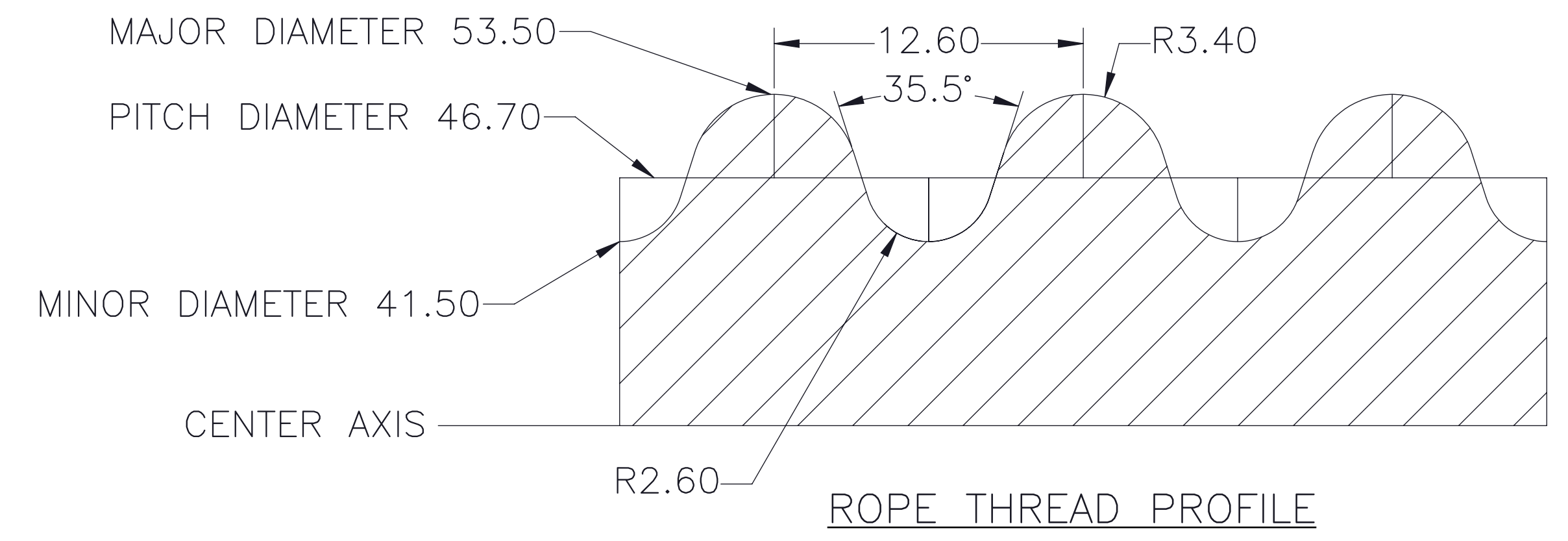

- NOTES:**
1. ALL DIMENSIONS IN MILLIMETERS
  2. ROPE THREAD DIMENSIONS FROM DRAWING SOF-A012
  3. DIMENSIONAL TOLERANCE  $\pm 0.125$  MM
  4. ANGULAR TOLERANCE  $\pm 0.5$
  5. MATERIAL: 1018 CARBON STEEL

REV	DATE	BY	APP	DESCRIPTION

DESIGNED BY N. DUNCAN
DRAWN BY N. DUNCAN
CHECKED BY J. JONASEN
IN CHARGE J. JONASEN
DATE 10/15/2025

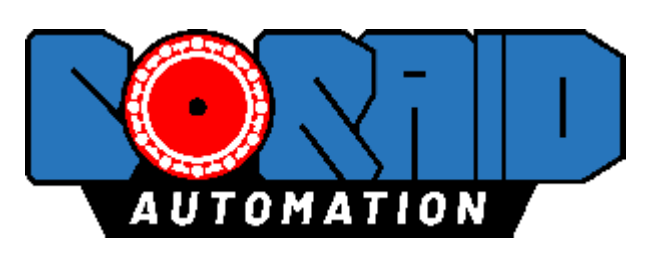

3050 E. AIRPORT WAY  
 LONG BEACH, CA 90806  
 562.264.2500

OPTIMAS-SOFRASAR TYPE 1 SOF LIFT 180		CATALOG NO.
LIFTING ATTACHMENT		2025-1253-MK01.01
LIFTING ATTACHMENT BASE		DRAWING NO. REV
		2025-1253 00
		SCALE
		2.5:1
		SHEET NO
		2

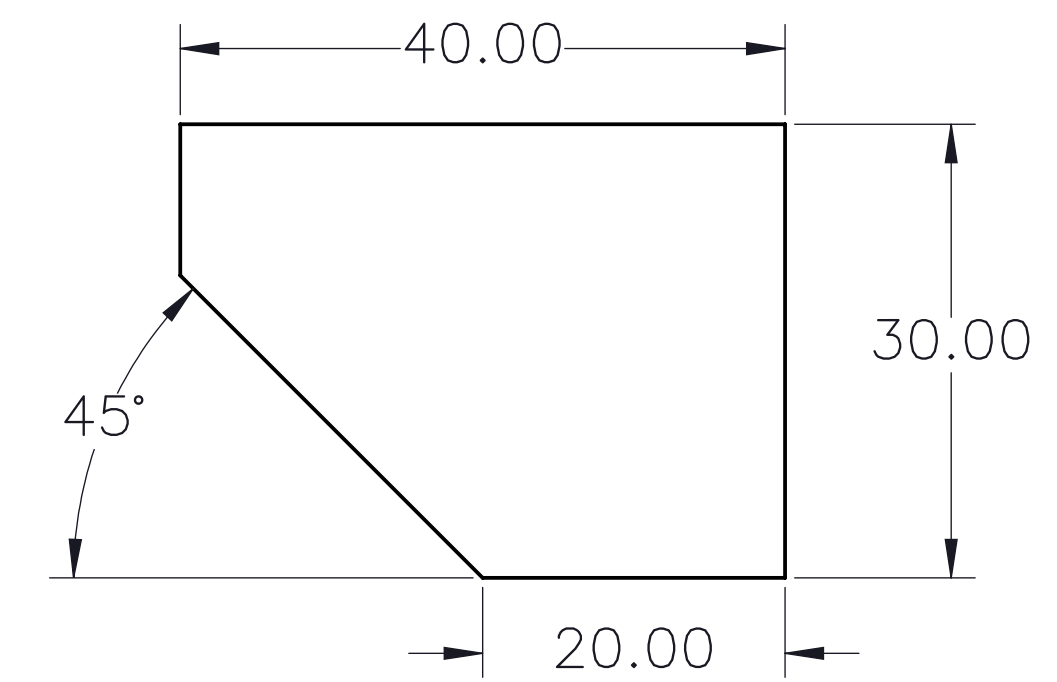
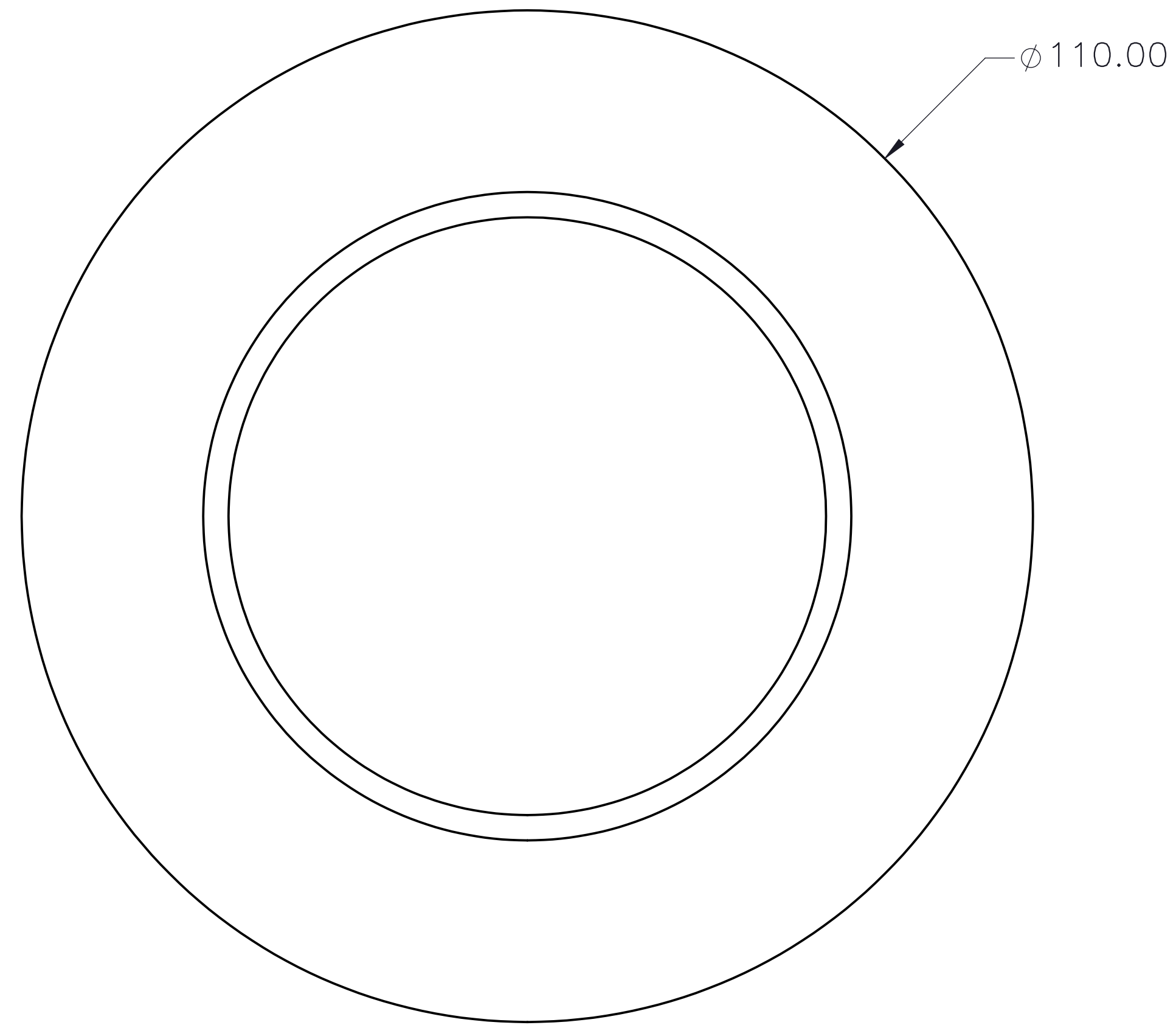

2025-1253-MK01.03-00 HAMMER TAB

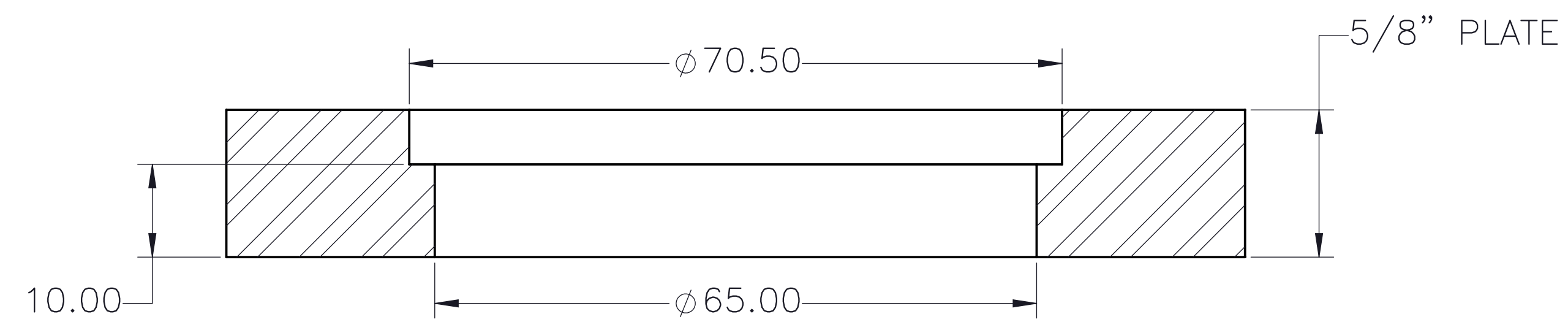

2025-1253-MK01.02-00 LIFTING INSERT FLANGE

- NOTES:**
1. FOR USE WITH SOFRASAR TYPE 1 SOF LIFT 180 PLASTIC PCTL INSERTS.
  2. ALL DIMENSIONS IN MILLIMETERS

REV	DATE	BY	APP	DESCRIPTION

DESIGNED BY	N. DUNCAN
DRAWN BY	N. DUNCAN
CHECKED BY	J. JONASEN
IN CHARGE	J. JONASEN
DATE	10/15/2025

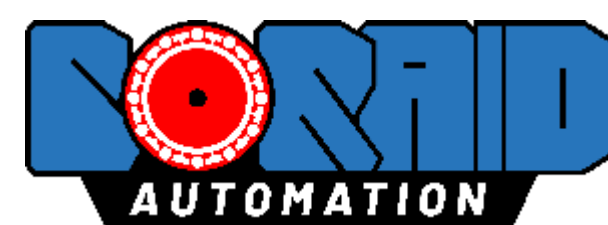

3050 E. AIRPORT WAY  
LONG BEACH, CA 90806  
562.264.2500

OPTIMAS-SOFRASAR TYPE 1 SOF LIFT 180 LIFTING ATTACHMENT	
ACCESSORY DETAILS	

CATALOG NO.	2025-1253-00
DRAWING NO.	2025-1253-00
SCALE	2:1
SHEET NO.	3

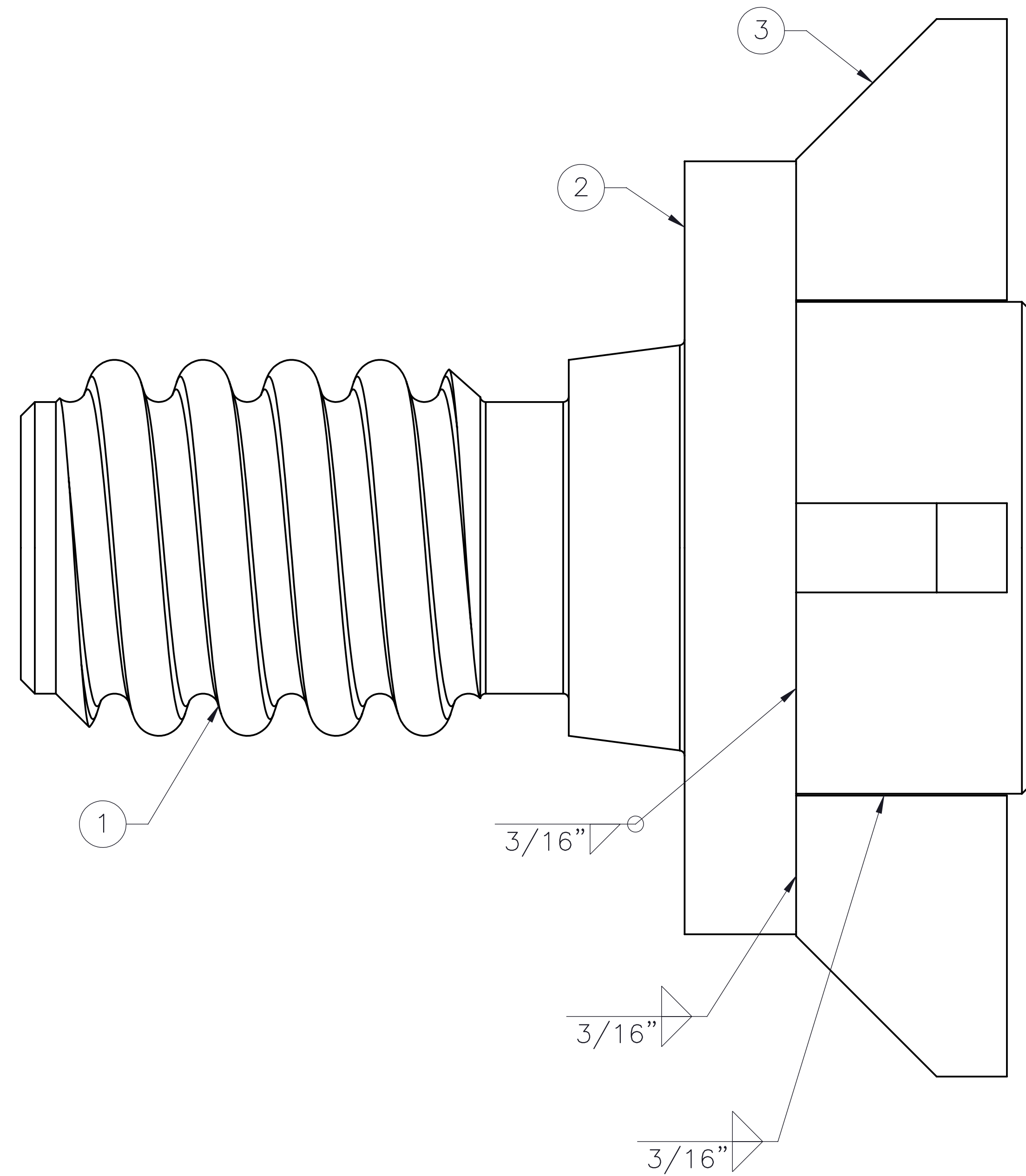

POS	QTY	PART NUMBER	SUPPLIER	DESCRIPTION	MATERIAL
1	1 EA	2025-1253-MK02.01	BORAID AUTOMATION	SOFRASAR TYPE 1/ZU GROUTING INSERT - BASE	1018
2	1 EA	2025-1253-MK01.02	BORAID AUTOMATION	SOFRASAR TYPE 1/ZU ATTACHMENT - FLANGE	1018
3	4 EA	2025-1253-MK01.03	BORAID AUTOMATION	SOFRASAR TYPE 1/ZU ATTACHMENT - HAMMER TAB	1018

**NOTES:** 1. FOR USE WITH SOFRASAR TYPE 1 SOF LIFT 180 PLASTIC PCTL INSERTS.

REV	DATE	BY	APP	DESCRIPTION

DESIGNED BY N. DUNCAN
DRAWN BY N. DUNCAN
CHECKED BY J. JONASEN
IN CHARGE J. JONASEN
DATE 10/15/2025

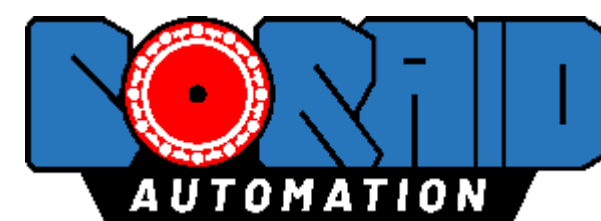

3050 E. AIRPORT WAY  
LONG BEACH, CA 90806  
562.264.2500

OPTIMAS-SOFRASAR TYPE 1 SOF LIFT 180 GROUTING ATTACHMENT		CATALOG NO. 2025-1253-MK02-00
ASSEMBLY DRAWING		DRAWING NO. 2025-1253
		REV 00
		SCALE 2:1
		SHEET NO 4

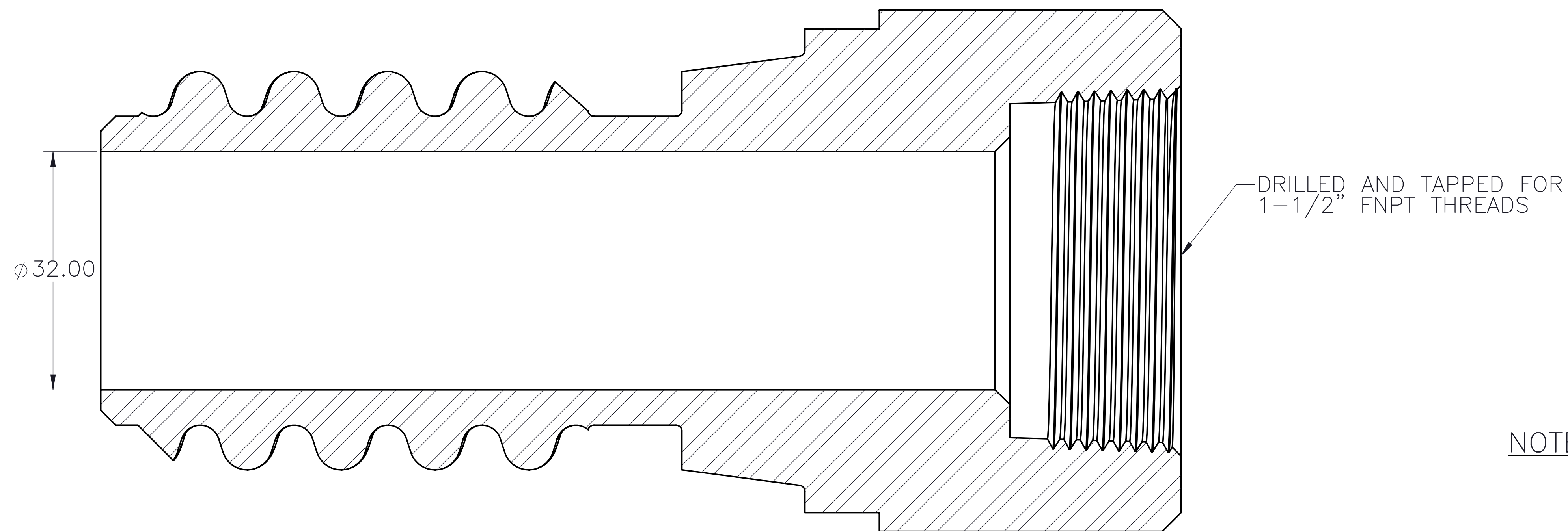
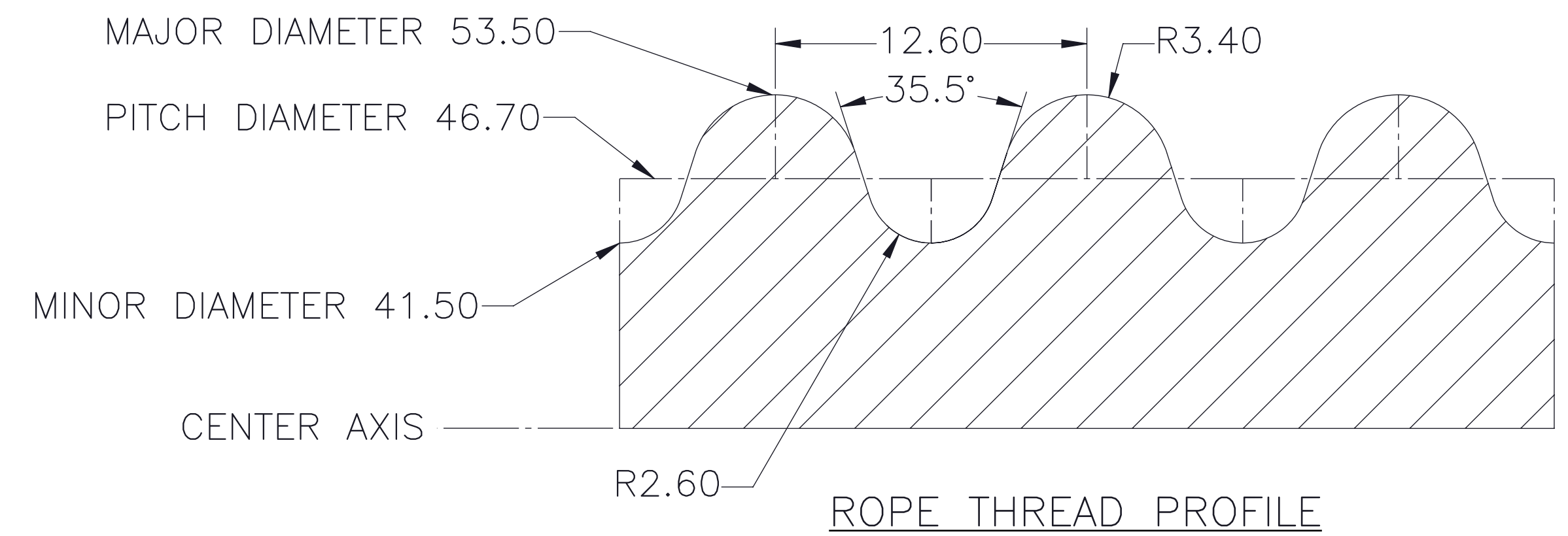
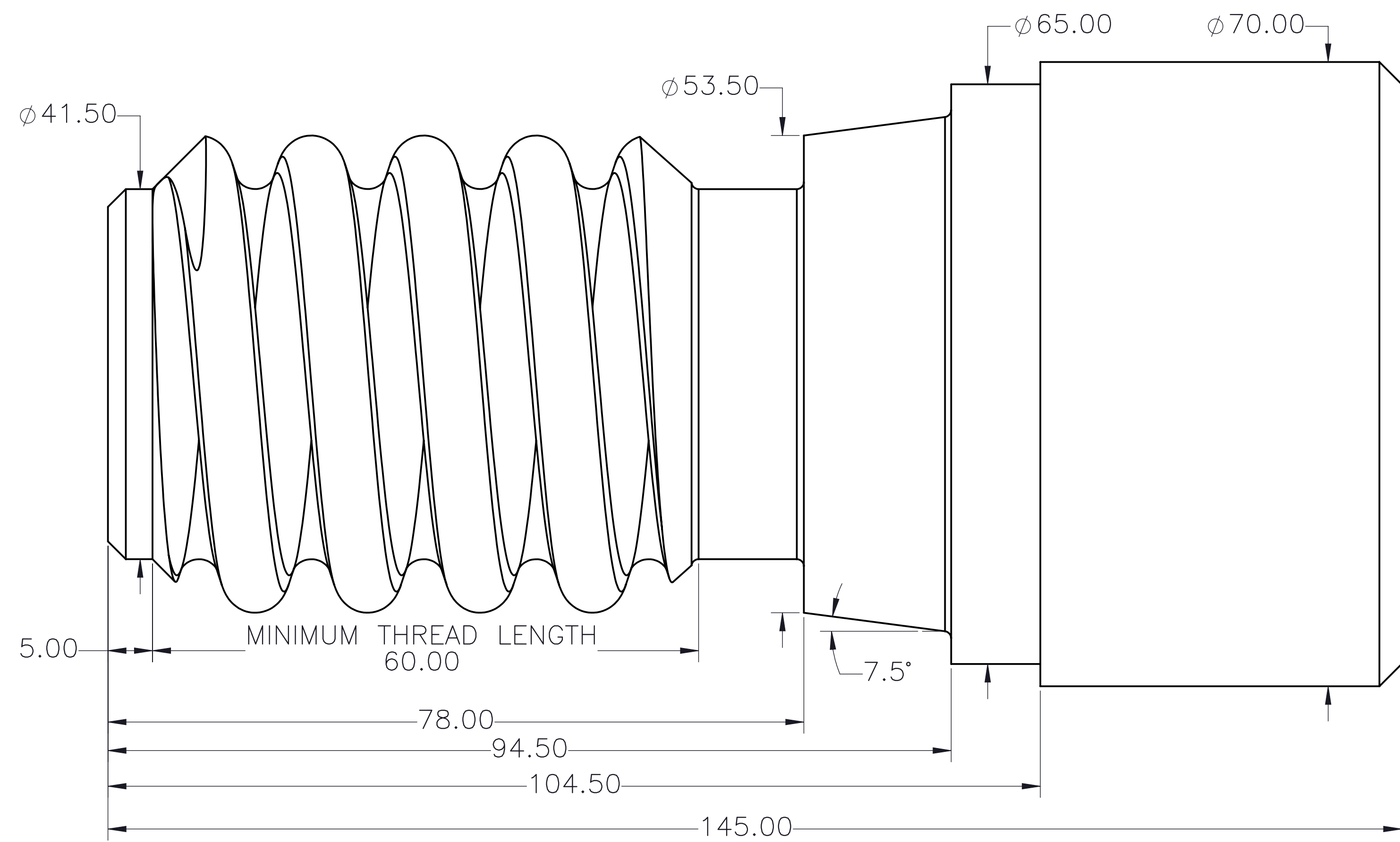

- NOTES:**
1. ALL DIMENSIONS IN MILLIMETERS
  2. ROPE THREAD DIMENSIONS FROM DRAWING SOF-A012
  3. DIMENSIONAL TOLERANCE  $\pm 0.125$  MM
  4. ANGULAR TOLERANCE  $\pm 0.5$
  5. MATERIAL: 1018 CARBON STEEL

REV	DATE	BY	APP	DESCRIPTION

DESIGNED BY	N. DUNCAN
DRAWN BY	N. DUNCAN
CHECKED BY	J. JONASEN
IN CHARGE	J. JONASEN
DATE	10/15/2025



3050 E. AIRPORT WAY  
 LONG BEACH, CA 90806  
 562.264.2500

OPTIMAS-SOFRASAR TYPE 1 SOF LIFT 180		CATALOG NO.	2025-1253-MK02.01
GROUTING ATTACHMENT		DRAWING NO.	2025-1253 00
GROUTING ATTACHMENT BASE		SCALE	2.5:1
		SHEET NO	5

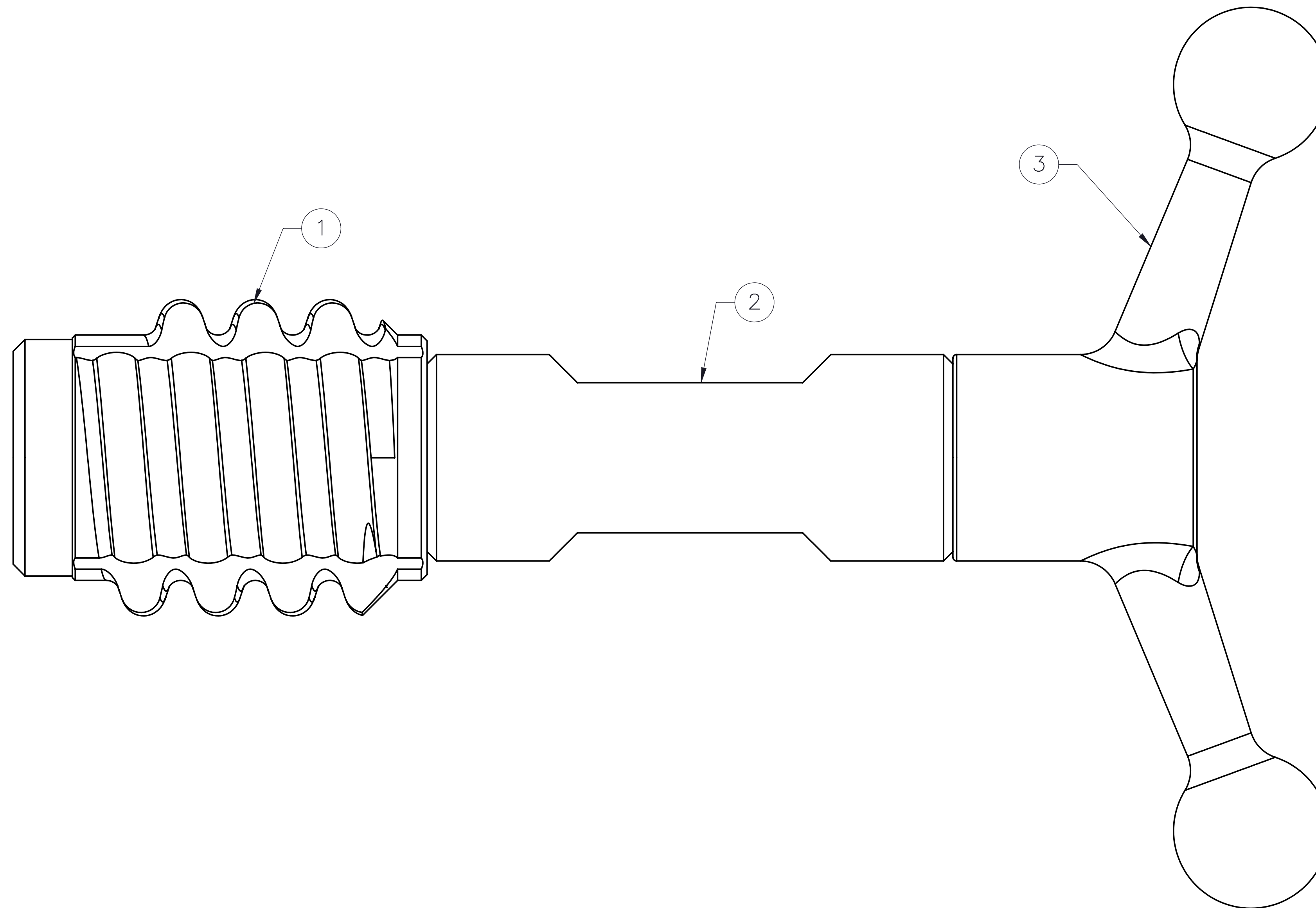

POS	QTY	PART NUMBER	SUPPLIER	DESCRIPTION	MATERIAL
1	1 EA	2025-1253-MK03.01	BORAID AUTOMATION	SOFRASAR TYPE 1/ZU THREAD CHASER	1018
2	1 EA	2025-1253-MK03.02	BORAID AUTOMATION	5 INCH THREAD CHASER EXTENSION	1018
3	1 EA	6422K46	MCMASTER CARR	THREADED THROUGH HOLE HANDLE	-

NOTES: 1. FOR USE WITH SOFRASAR TYPE 1 SOF LIFT 180 PLASTIC PCTL INSERTS.

REV	DATE	BY	APP	DESCRIPTION

DESIGNED BY	N. DUNCAN
DRAWN BY	N. DUNCAN
CHECKED BY	J. JONASEN
IN CHARGE	J. JONASEN
DATE	10/15/2025

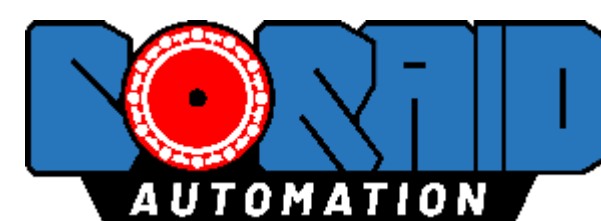

3050 E. AIRPORT WAY  
LONG BEACH, CA 90806  
562.264.2500

OPTIMAS-SOFRASAR TYPE 1 SOF LIFT 180 THREAD CHASER ATTACHMENT	
ASSEMBLY DRAWING	

CATALOG NO.	2025-1253-MK03-00
DRAWING NO.	2025-1253-00
SCALE	2:1
SHEET NO	6

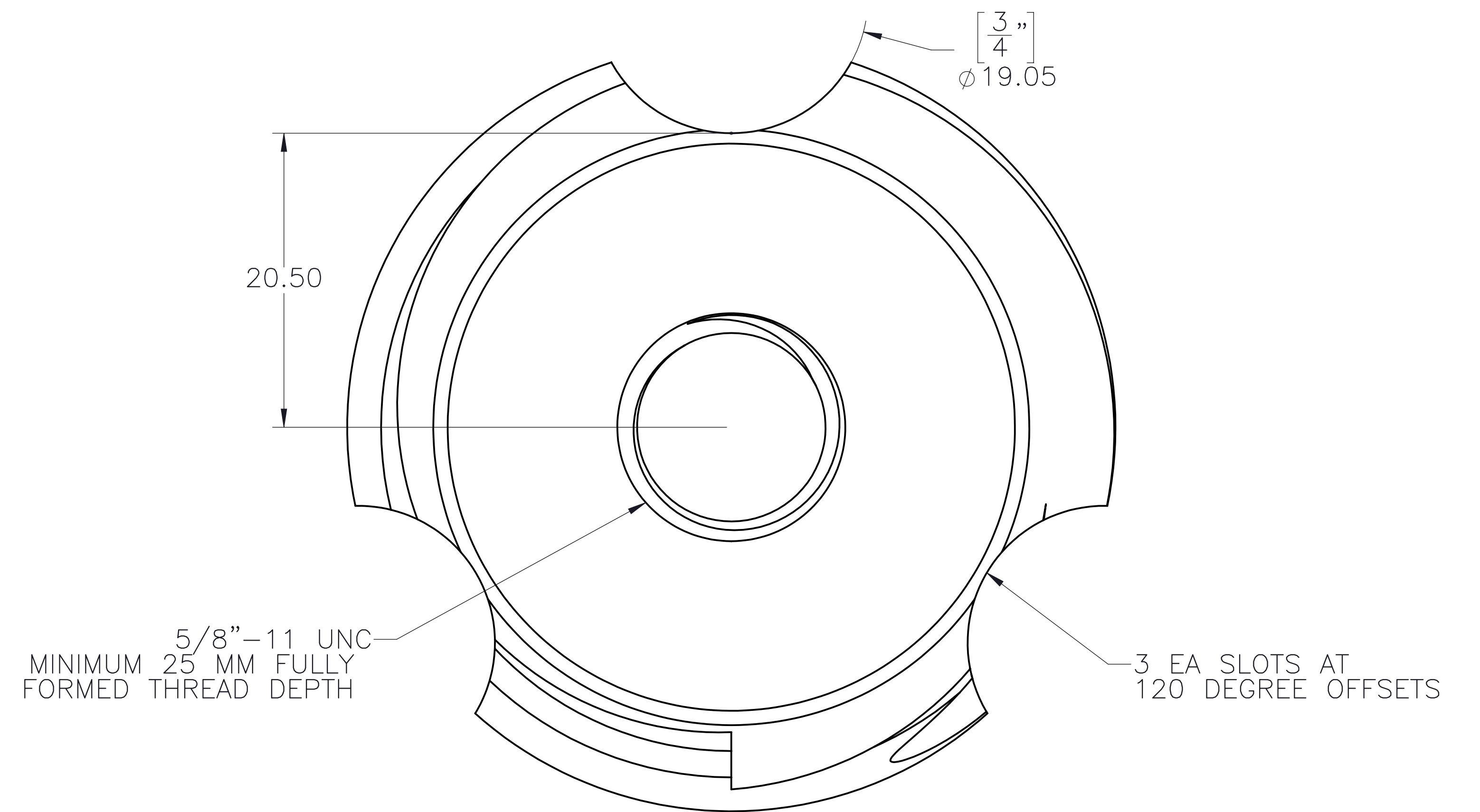
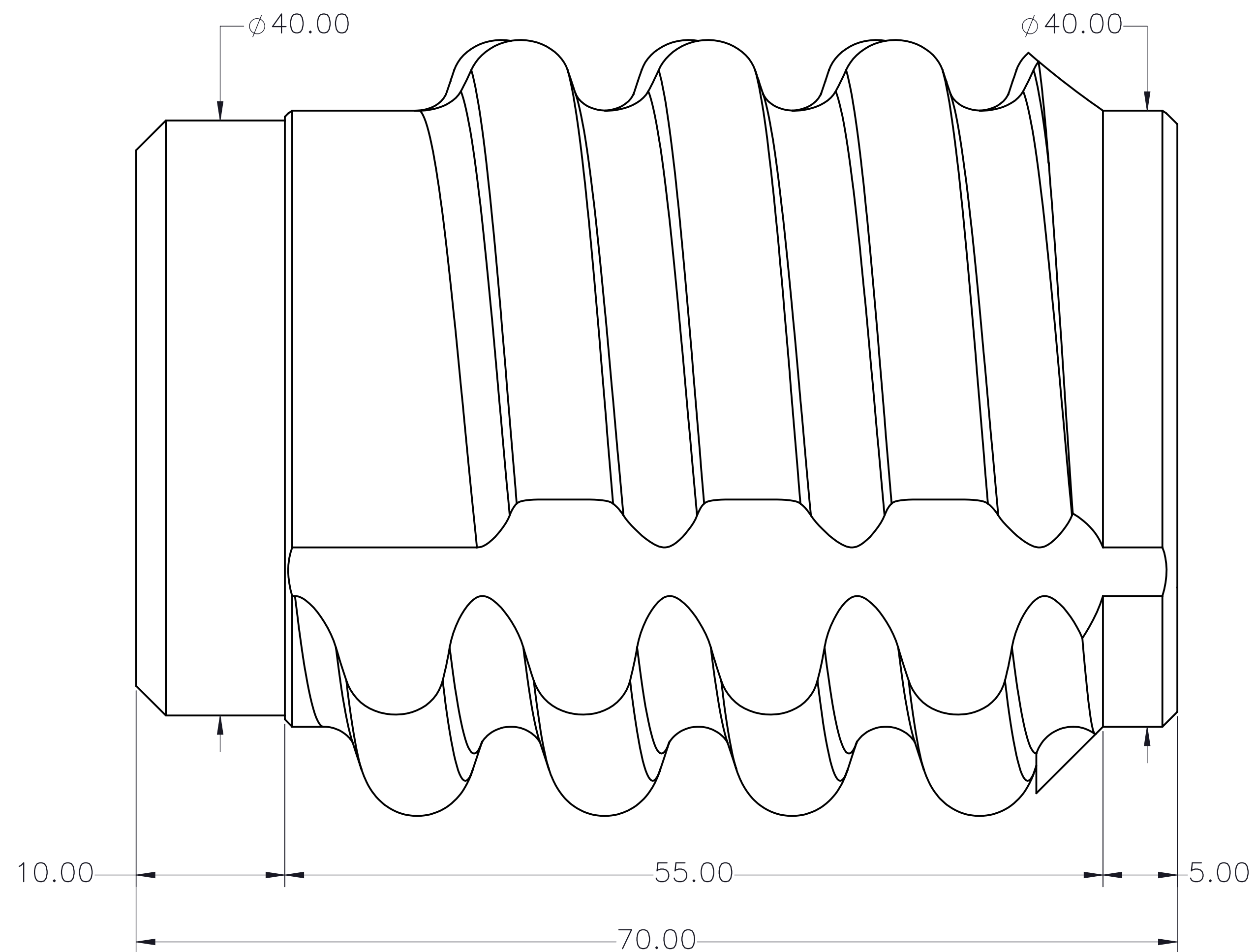
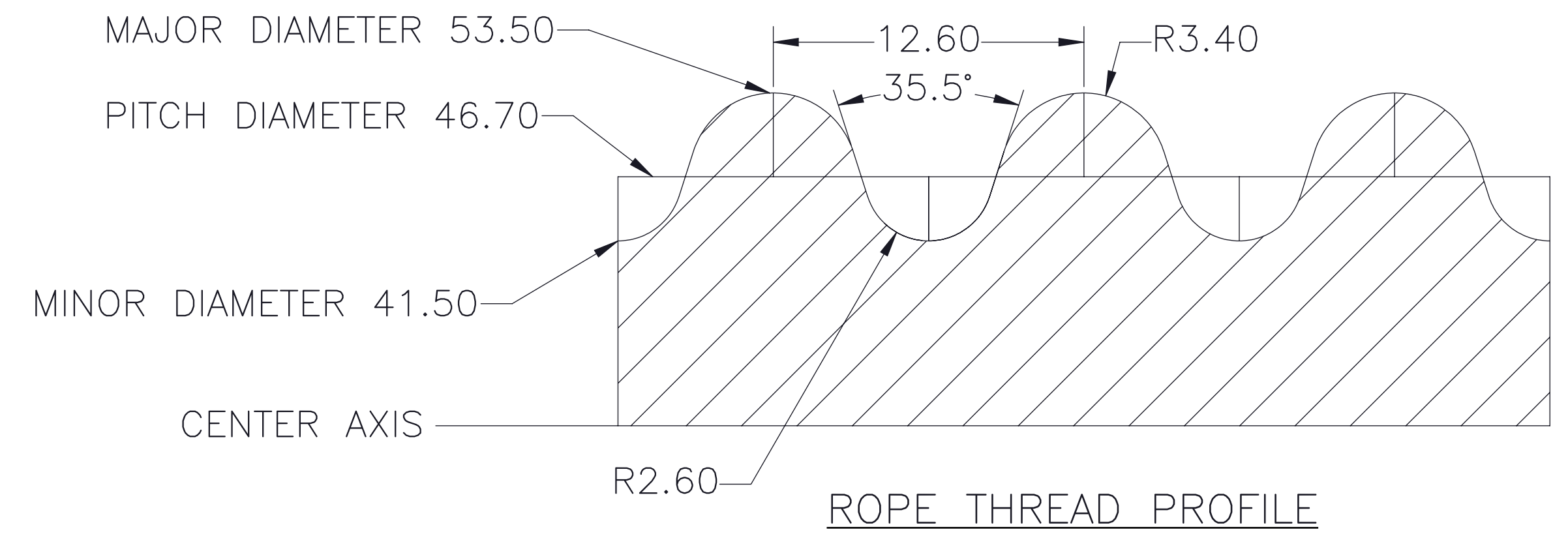

**NOTES:** 1. FOR USE WITH SOFRASAR TYPE 1 SOF LIFT 180 PLASTIC PCTL INSERTS.  
 2. MATERIAL: 1018 LOW CARBON STEEL  
 3. ALL DIMENSIONS IN MILLIMETERS

REV	DATE	BY	APP	DESCRIPTION

DESIGNED BY N. DUNCAN
DRAWN BY N. DUNCAN
CHECKED BY J. JONASEN
IN CHARGE J. JONASEN
DATE 10/15/2025



3050 E. AIRPORT WAY  
 LONG BEACH, CA 90806  
 562.264.2500

OPTIMAS-SOFRASAR TYPE 1 SOF LIFT 180 THREAD CHASER ATTACHMENT		CATALOG NO. 2025-1253-MK03.01
THREAD CHASER BASE		DRAWING NO. 2025-1253
		REV 00
		SCALE 4:1
		SHEET NO 7

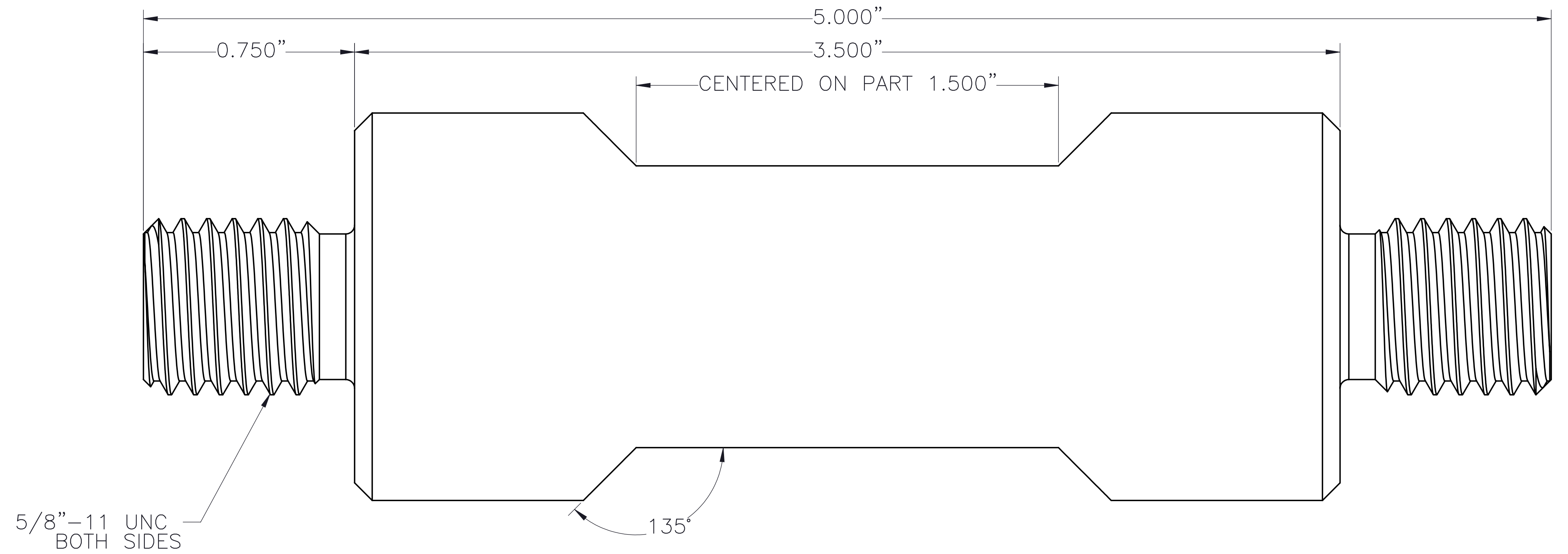
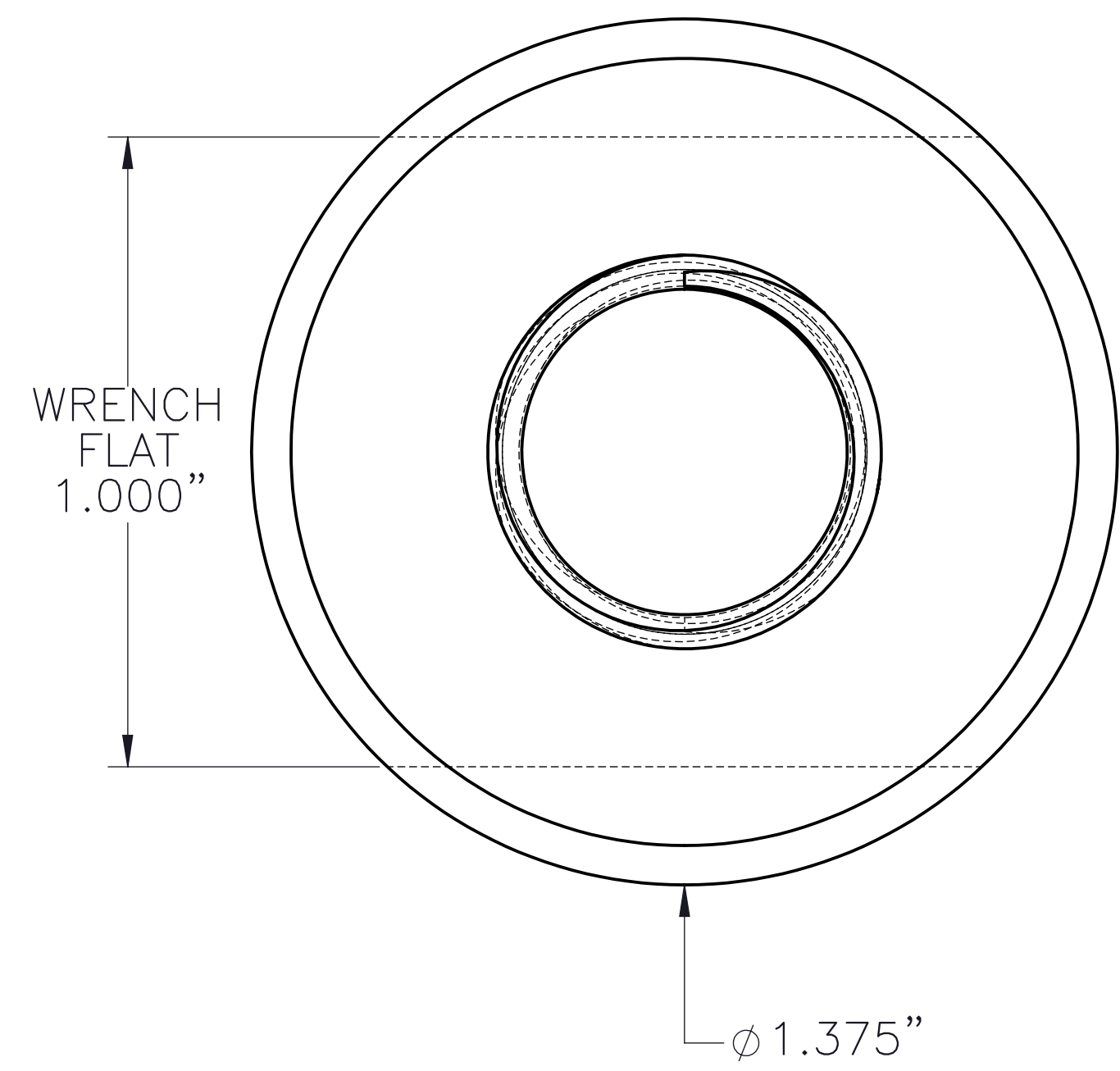

- NOTES:**
1. FOR USE WITH SOFRASAR TYPE 1 SOF LIFT 180 PLASTIC PCTL INSERTS.
  2. MATERIAL: 1018 LOW CARBON STEEL
  3. ALL DIMENSIONS IN INCHES

REV	DATE	BY	APP	DESCRIPTION

DESIGNED BY	N. DUNCAN
DRAWN BY	N. DUNCAN
CHECKED BY	J. JONASEN
IN CHARGE	J. JONASEN
DATE	10/15/2025

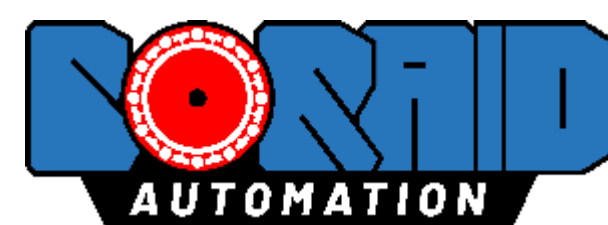

3050 E. AIRPORT WAY  
 LONG BEACH, CA 90806  
 562.264.2500

OPTIMAS-SOFRASAR TYPE 1 SOF LIFT 180 THREAD CHASER ATTACHMENT		CATALOG NO.	2025-1253-MK03.02
5 INCH THREAD CHASER EXTENSION		DRAWING NO.	2025-1253
		REV	00
		SCALE	4:1
		SHEET NO	8